

Staticmaster® Auto-Balanced Dual-Speed Ionizing Fan



TECHNOLOGY
& LAB



INDUSTRIAL

MODEL NUMBER 6212

CORONA



The Staticmaster® Auto-Balanced Dual-Speed Ionizing Fan utilizes NRD's auto-balancing technology, making it **ideal for semiconductor backend, printed circuit board assembly and general electronic applications.**

The Model 6212 is easy to use and maintain as it does not require periodic calibration to maintain its low offset voltage balance. The Facility Monitoring System (FMS) interface also allows real-time ionizer status monitoring and provides a visual and audio alarm for ionizer malfunctions or power down.

APPLICATIONS

- PCB, BEOL, electronic assembly, molded parts, roll film, medical devices, injection molding

FEATURES

- Auto-balance Technology
- Steady-State DC Technology
- FMS (Facility Monitoring System)
- Operation and Alarm LED Indicator
- Low/high speed fan

BENEFITS

- No calibration required
- Ability to monitor ionizers
- Audio Fail Alarm
- Airflow can be adjusted to work process

EVERY SITUATION IS UNIQUE. SO IS EVERY SOLUTION.™



Staticmaster® Auto-Balanced Dual-Speed Ionizing Fan

MODEL NUMBER 6212

CORONA

SCHEMATICS

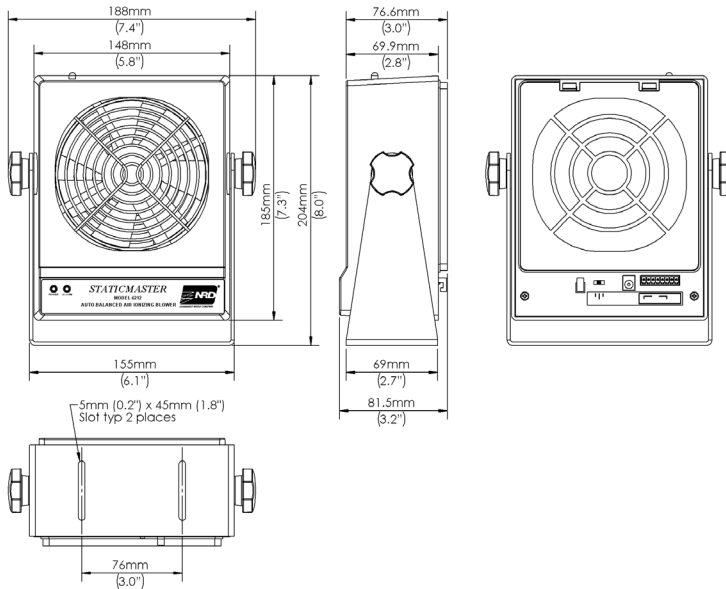

MAINTENANCE

It is necessary to clean and balance ionizer regularly. Clean emitter points as needed.

NOTICE: NRD expressly warrants that, for a period of one (1) year from the time of purchase, the ionizer will be free of defects in material (parts) and workmanship (labor).

SPECIFICATIONS

Airflow: 140 CFM (66.07 L/s)

Alarm Function: Audio/LED alarm at HV Power failure

Balance: ± 20 V

Dimensions: 2.5in W x 6.1in H x 6in L (64 mm x 154.5 mm x 152 mm)

Emitter Point: Tungsten 99.99%

Enclosure: ABS, Aluminum Bracket

LED Indicators: Green - Power On; Red - Alarm

Operating Humidity: 35-85%

Output Monitoring: FMS Interface

Power Supply Input Voltage: 24 V DC

Technology: Corona

Weight: 34.56 oz (980 g)

DECAY RATE: 2 seconds (± 1000 to 100V), ANSI/ESD Association STM 3.1 @ 1 foot, center

NRD, LLC USA

800-525-8076
716-773-7634
Sales@NRDUSA.com
2937 Alt Boulevard
PO Box 310
Grand Island, NY
14072-0310 USA

NRD Asia Pte. Ltd.

+65 6679 1707
Sales@NRDAsia.com
114 Lavender Street
#08-90 CT Hub 2
Singapore 338729